



HCT060 ATHLETIC WASHER-EXTRACTOR

BID SPECIFICATIONS

Working Capacity: 60lbs.

1. Overall Dimensions: The maximum width of the machine shall be 34.1" to allow the machine to fit through a standard 36" doorway. The maximum height of the machine shall be 49.9". The maximum depth of the machine shall be 46.7". The minimum weight of the machine shall be 680 lbs.

2. Cylinder: The cylinder shall be of a welded construction with a minimum inside diameter of 30" and minimum depth of 22". Total cylinder volume shall be a minimum of 9 cubic feet. The cylinder shall be entirely constructed of stainless steel (type 304). No carbon steel shall be used.

3. Outer Tub Shell: The shell shall be constructed entirely of stainless steel (type 304). The shell front shall be removable.

4. Front Panel: The front panel shall be constructed of stainless steel (type 304) and include a lower removable panel to facilitate front access maintenance.

5. Door: The door shall be constructed of stainless steel, no painted metal or plastic shall be permitted. The door opening shall be a minimum of 16.3" in diameter and shall have heat treated, high tensile strength glass capable of withstanding high mechanical action and thermal shock.

6. Door Safety Interlocks: The door safety interlocks shall prevent operation of the machine unless the outer door is closed and locked. It shall prevent the opening of the door unless the cylinder has stopped, the temperature inside the shell is at a safe level and the water is below a safe level.

7. Door Handle: The door handle shall be constructed of metal with chrome plating for strength and longevity with no actuating buttons or levers. No plastic or rubber parts shall be permitted in the door handle. The handle should be at the 3 o'clock position when closed and 6 o'clock position when opened.

8. Drive System: The machine shall have a maximum of one (1) drive motor to power the machine at all operating speeds. The motor shall be a maximum of 3 HP powered by a variable frequency drive.

9. Washer Frame: The frame shall be heavy-duty structural steel (no galvanized metal shall be permitted). All frame components shall be welded (no pop-rivets or "cinch" methods shall be permitted).

10. Bearing Housing: The cylinder shaft shall be constructed of steel and be supported by 2 permanently sealed bearings contained in a single housing. The housing shall be sealed from water by a minimum of 1 excluder seal, 2 triple lip seals and 1 retaining ring. Two weep holes shall prevent water from reaching the bearings in case of a seal failure.

11. Out of Balance Detection: Out of balance loads shall be determined electronically by the drive system.

12. Control: The control shall be fully programmable including water levels, water temperatures, wash agitation timing and speed. Programming must be wireless to avoid exposing internal connection points to contamination. Keypad must be easily field replaceable without needing to replace the entire control.

13. Agency Approvals: CE, ETL

14. Warranty: A 3 year parts only warranty covers the complete machine with a 5 year parts only warranty covering the bearings, seals, bearing housing, outer tub shell, frame, cylinder and shaft. All warranties start from date of install. Warranties do not cover vandalism, acts of god, misuse or damage resulting from chemical leaks.

HCT060 ATHLETIC LAUNDRY SYSTEMS

60 POUND CAPACITY
HARDMOUNT WASHER-EXTRACTOR

1-800-327-4782

3611 E. Croft Circle
Spartanburg, SC 29302

www.athleticls.com

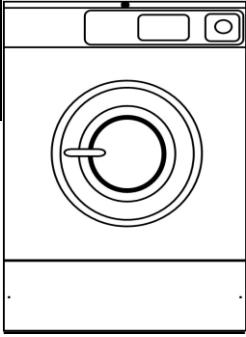

WORKLOAD:

- 90 TOWELS
- 60 FOOTBALL JERSEYS
- 45 FOOTBALL PANTS

Control	Athletic 400	
Capacity	60 lbs. Dry Weight	
Overall Width	34.1"	
*Overall Depth	46.7"	
Overall Height	49.9"	
Cylinder Diameter	30"	
Cylinder Depth	22"	
Cylinder Volume	9 cu. ft.	
Door Opening Size	16.3"	
Door Bottom to Floor	14.9"	
Water Inlet Connection	4 @ 3/4"	
Drain Diameter	1 @ 3"	
Drain Height to Floor	4.9" to Center	
Motor Power Consumption	3 hp	
Cylinder Speeds RPM (G-Force)	Gentle	31 (0.4)
	Wash	43 (0.8)
	Distribution	77 (2.5)
	Very Low	252 (27)
	Low	434 (80)
	Medium	485 (100)
	**High	542 (125)
**Very High	594 (150)	
**Ultra High	686 (200)	

Voltage/ Circuit Breaker/ FLA	B	120/60/1	N/A
	X	200-240/60 1 or 3 phase	15-11 (1 Phase) 15-7 (3 Phase)
	P	380-415/60/3	15-4
	N	440-480/60/3	15-4

Shipping Dimensions	Width	37.5"
	Depth	46.9"
	Height	56.3"

Net Weight	680 lbs.
Shipping Weight	720 lbs.

Agency Approvals



* Overall depth includes drain outlet to door handle

**High, very high and ultra high speed extract available only on V speed washers

Front View

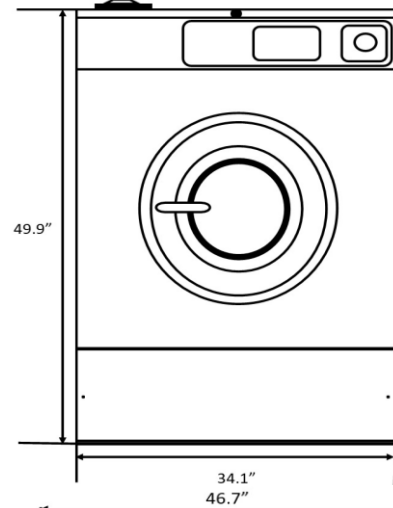

Side View

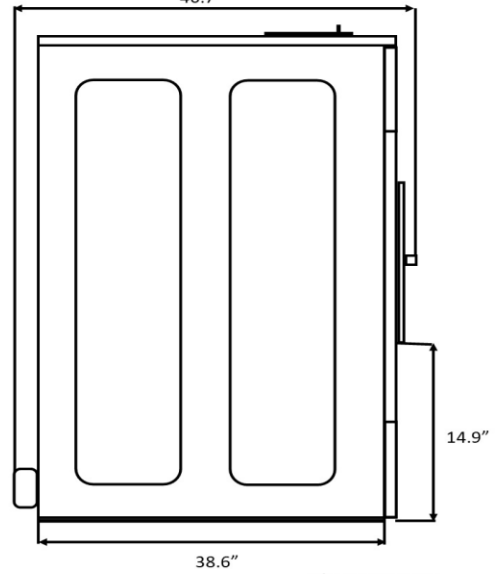

Rear View

