



## HCT080 ATHLETIC WASHER-EXTRACTOR

### BID SPECIFICATIONS

Working Capacity: 80lbs.

**1. Overall Dimensions:** The maximum width of the machine shall be 41.5". The maximum height of the machine shall be 57.2". The maximum depth of the machine shall be 48.2". The minimum weight of the machine shall be 1,250 lbs.

**2. Cylinder:** The cylinder shall be of a welded construction with a minimum inside diameter of 36" and minimum depth of 21.9". Total cylinder volume shall be a minimum of 12.9 cubic feet. The cylinder shall be entirely constructed of stainless steel (type 304). No carbon steel shall be used.

**3. Outer Tub Shell:** The shell shall be constructed entirely of stainless steel (type 304). The shell front shall be removable.

**4. Front Panel:** The front panel shall be constructed of stainless steel (type 304) and include a lower removable panel to facilitate front access maintenance.

**5. Door:** The door shall be constructed of stainless steel, no painted metal or plastic shall be permitted. The door opening shall be a minimum of 18.5" in diameter and shall have heat treated, high tensile strength glass capable of withstanding high mechanical action and thermal shock.

**6. Door Safety Interlocks:** The door safety interlocks shall prevent operation of the machine unless the outer door is closed and locked. It shall prevent the opening of the door unless the cylinder has stopped, the temperature inside the shell is at a safe level and the water is below a safe level.

**7. Door Handle:** The door handle shall be constructed of metal with chrome plating for strength and longevity with no actuating buttons or levers. No plastic or rubber parts shall be permitted in the door handle. The handle should be at the 3 o'clock position when closed and 6 o'clock position when opened.

**8. Drive System:** The machine shall have a maximum of one (1) drive motor to power the machine at all operating speeds. The motor shall be a maximum of 5 HP powered by a variable frequency drive.

**9. Washer Frame:** The frame shall be heavy-duty structural steel (no galvanized metal shall be permitted). All frame components shall be welded (no pop-rivets or "cinch" methods shall be permitted).

**10. Bearing Housing:** The cylinder shaft shall be constructed of steel and be supported by 2 permanently sealed bearings contained in a single housing. The housing shall be sealed from water by a minimum of 1 excluder seal, 2 triple lip seals and 1 retaining ring. Two weep holes shall prevent water from reaching the bearings in case of a seal failure.

**11. Out of Balance Detection:** Out of balance loads shall be determined electronically by the drive system.

**12. Control:** The control shall be fully programmable including water levels, water temperatures, wash agitation timing and speed. Programming must be wireless to avoid exposing internal connection points to contamination. Keypad must be easily field replaceable without needing to replace the entire control.

**13. Agency Approvals:** CE, ETL

**14. Warranty:** A 3 year parts only warranty covers the complete machine with a 5 year parts only warranty covering the bearings, seals, bearing housing, outer tub shell, frame, cylinder and shaft. All warranties start from date of install. Warranties do not cover vandalism, acts of god, misuse or damage resulting from chemical leaks.

# HCT080 ATHLETIC LAUNDRY SYSTEMS

1-800-327-4782

3611 E. Croft Circle  
Spartanburg, SC 29302



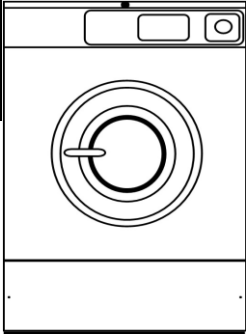

www.athleticls.com



80 POUND CAPACITY  
HARDMOUNT WASHER-EXTRACTOR

**WORKLOAD:**

- 120 TOWELS
- 80 FOOTBALL JERSEYS
- 60 FOOTBALL PANTS

|   |                    |   |                 |
|---|--------------------|---|-----------------|
| Control   | Athletic 400       |   |                 |
| Capacity  | 80 lbs. Dry Weight |   |                 |
| Overall Width   | 41.5"              |   |                 |
| *Overall Depth  | 48.2"              |   |                 |
| Overall Height  | 57.2"              |   |                 |
| Cylinder Diameter   | 36"                |   |                 |
| Cylinder Depth  | 21.9"              |   |                 |
| Cylinder Volume   | 12.9 cu. ft.       |   |                 |
| Door Opening Size   | 18.5"              |   |                 |
| Door Bottom to Floor  | 17.9"              |   |                 |
| Water Inlet Connection  | 4 @ 3/4"           |   |                 |
| Drain Diameter  | 1 @ 3"             |   |                 |
| Drain Height to Floor   | 5.1" to Center     |   |                 |
| Motor Power Consumption   | 5 hp               |   |                 |
| Cylinder Speeds<br>RPM (G-Force)  | Gentle             | 28 (0.4)  |                 |
|   | Wash               | 39 (0.8)  |                 |
|   | Distribution       | 70 (2.5)  |                 |
|   | Very Low           | 230 (27)  |                 |
|   | Low                | 396 (80)  |                 |
|   | Medium             | 443 (100)   |                 |
|   | **High             | 495 (125)   |                 |
|   | **Very High        | 542 (150)   |                 |
| **Ultra High  | 626 (200)          |   |                 |
| Voltage/<br>Circuit   | B                  | 120/60/1  | N/A             |
|   | X                  | 200-240/60  | 20-15 (1 Phase) |
|   |                    | 1 or 3 phase  | 15-9 (3 Phase)  |
|   | Breaker/<br>FLA    | P   | 380-415/60/3    |
| N   |                    | 440-480/60/3  | 15-6            |
| Shipping<br>Dimensions  | Width              | 44"   |                 |
|   | Depth              | 54.5"   |                 |
|   | Height             | 59.6"   |                 |
| Net Weight  | 1250 lbs.          |   |                 |
| Shipping Weight   | 1300 lbs.          |   |                 |
| Agency Approvals  |                    |   |                 |
|  |                    |  |                 |

Front View

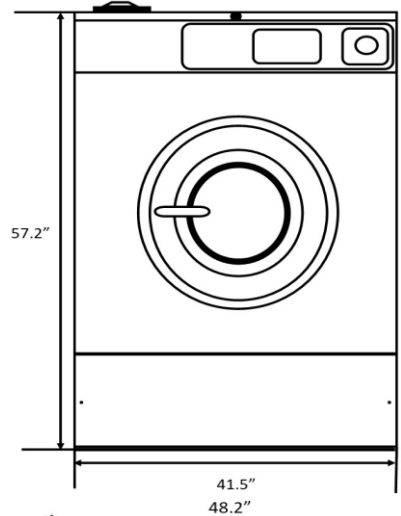

Side View

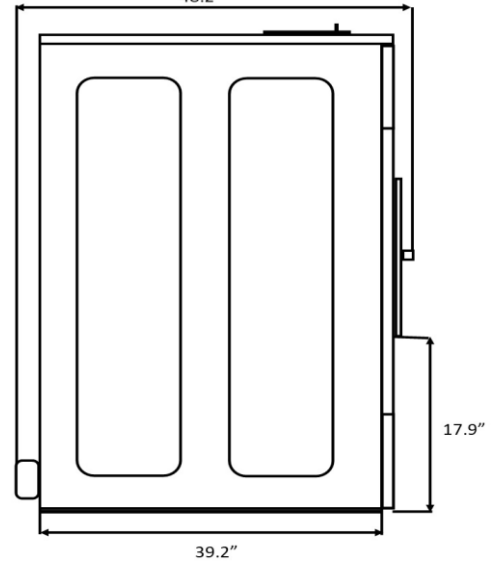

Rear View

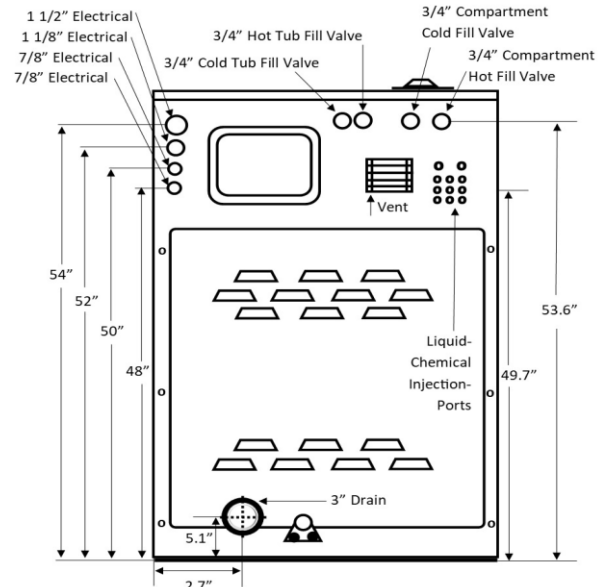

\* Overall depth includes drain outlet to door handle

\*\*High, very high and ultra high speed extract available only on V speed washers