

# Machine Dimensions and Specifications

Model HT075N 75lb. Capacity Athletic Drying Tumbler  
Natural Gas or Propane Gas Heat Source



Equipment specifications are subject to change without notice.

## Dimensions

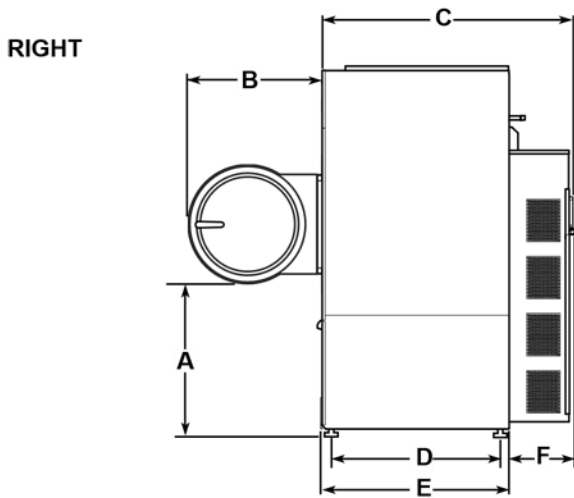

A	29.2 [740]	L	5.0 [130]
B	33.9 [860]	M	38.5 [980]
C	53.0 [1350]	N	15.0 [380]
D	35.5 [900]	O	8.0 [200]
E	39.2 [1000]	P	5.8 [145]
F	13.8 [350]	Q	6.0 [150]
G	77.3 [1960]	R	33.0 [840]
H	66.0 [1680]	S	6.2 [160]
I	57.5 [1460]	T	7.7 [200]
J	55.0 [1400]	U	36 [910]
K	42.2 [1070]		
in. [mm]			

## Specifications

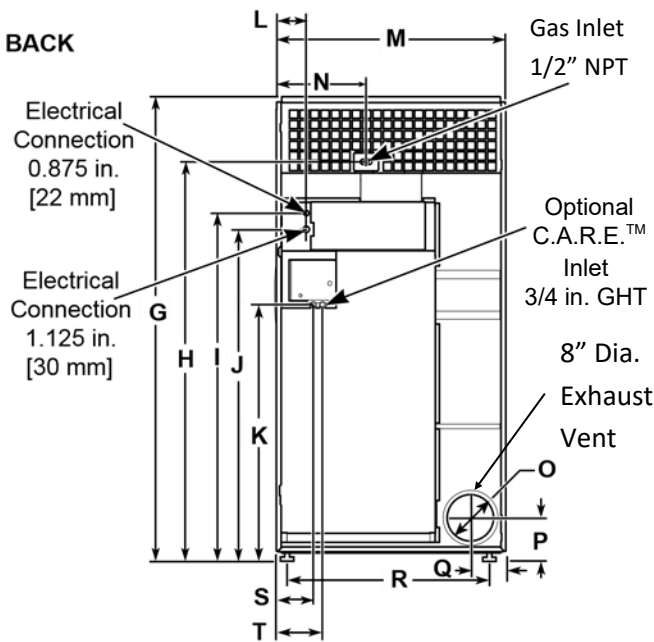

Net Weight (approximate): Pounds [kg]	680 [310]
Required Make-Up Air Opening (to the outside) for Each Tumble Dryer, in. <sup>2</sup> [cm <sup>2</sup> ]	195 [1,260]
Maximum Airflow: C.F.M. [l/sec]	800 [380]
Maximum Static Back Pressure: Inch W.C. [mbar, kPa]	0.50 [1.2, 0.12]
Gas Burner Rating: BTU/hr. [kW, Mj/hr.]	165,000 [48.4, 174]

## Electrical Specifications

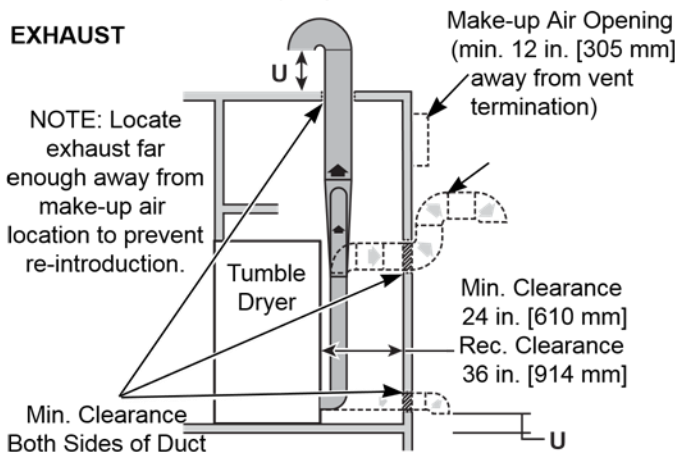

Voltage Code	Voltage	Cycle	Phase	Wire	Full Load Amps	Circuit Breaker	Wire Size AWG [mm <sup>2</sup> ]
B	100-120	50-60	1	L1, Neutral, and ground	12	15	14 [2.5]
X	200-240	50-60	1	L1, L2 and ground	7	15	14 [2.5]
			3	L1, L2, L3 and ground			
N	440-480	50-60	3	L1, L2, L3 and ground	3	15	14 [2.5]

WWW.ATHLETICLS.COM

1-800-327-4782

SALES@ATHLETICLS.COM